

Temperature Effect and Battery Charging Characteristics Analysis Based on Charging C-Rate

Md. Sazib Mollik, M M Rashid, A Rahman, A Hasan

Abstract: Developing fast charging properties for LiFePo4 battery is a key issue for a wider deployment of EV. The main drawback of LiFePo4 battery charging is overcharge, overcurrent and high temperature which affects longevity, efficiency, and battery life cycle. In this research, lithium iron phosphate (LiFePo4) battery is investigated for fast, and rapid charging with CC-CV principle. MATLAB/Simulink based custom-designed tool was developed. A dynamic model of lithium-ion phosphate battery is proposed in this research by considering the significant temperature and capacity fading effects. Results have shown that the LiFePo4 battery can be used for fast charging up to 100% and rapid charging up to 85% by maintaining the condition for lifespan of the battery and to shorten the charging time. The simulation results have been showed that, the constructed model can really represent the dynamic performance feature of the lithium-ion battery. The modified model can assess the efficiency of battery execution based on charging C-rate conditions.

Keywords: Lithium-ion battery, battery model, SOC, temperature and Simulation

I. INTRODUCTION

The Lithium-ion battery has supremely utilized for the electric vehicles, because of its outstanding execution characteristics, for instance high energy density, long life-time and low self-discharge [1-3]. Li-ion batteries are projected to be the most standard battery for electric vehicles, especially in plug-in hybrid electric vehicles (PHEVs) and battery electric vehicles (BEVs), due to their potential of obtaining higher specific energy and specific power. Particular energy is the vitality capacity which a battery can hold in watt-hours per kilogram (Wh/kg) and particular control is the capacity of a battery to provide control in watts per kilogram (W/kg)[4, 5]. A higher specific energy means longer runtime and a higher specific power means the battery can deliver more power. There are three popular cathode materials for the Li-Ion battery, which is LiCoO₂, LiMn₂O₄, and LiFePO₄. LiCoO₂ is the most commonly used in

consumer products such as in notebook computer. This battery has better cycle life and good capacity however it is very exclusive and insecure upon fast charge. LiMn₂O₄ is low-cost type and commonly used in cell phones. Its power capability is very low, and its calendar life and cycle life are very poor. LiFePO₄ has enhancements in both abuse tolerance and power capability. It also tolerates from short calendar life, low energy, capacity, and voltage. [5-7].

There are common charging methods for Electric vehicles batteries which are constant voltage (CV), constant current (CC), and combination of both. The battery has been charged at a steady current until its voltage has been come to the pre-determined restrain taken after by a consistent voltage until the current diminishes to a pre-determined low value. This charging process is called constant current-constant voltage (CC-CV) charging method [5, 8, 9]. The SOC is a vital parameter, accurate estimation can not only help to prevent the cells from overcharge and under discharge but also help to improve battery life cycle and performance and to develop the control strategy. the state of charge (SOC) is the amount of remaining capacity with respect to full capacity during the charging and discharging cycles. Most of the time in the SOC estimation methods, such as battery over current and time is considered. Battery life-time depends on battery charging technique which is the most imperative aspect of this matter, charging technique has ability to control the charging time, temperature, and SOC it has capability to secure the battery from expanding or diminishing of charging process [10, 11]. The design and accessories of this electric vehicles are including battery, controller and motor [6]. However, the predictable charging procedures are more simple but it has some drawbacks like as long charging time, heat generation during charging time, over and under charging. Thus, there are several types of conventional charging methods like as constant current, two-step current, constant voltage, constant current-constant voltage, and reflex are more crucial not only to extend the life of the battery but also to reduce the charging time and temperature.

MATLAB/Simulink is one of the most analytical simulation tools which can be designed not only electrical circuit but also system designs. It affords lots of straightforward, powerful and accessible toolboxes or simulation blocks. MATLAB/Simulink library provides a battery model.

Revised Manuscript Received on October 20, 2019.

* Correspondence Author

Md. Sazib Mollik*, Department of Mechatronics Engineering, International Islamic University Malaysia. Email: sazib000mollik@gmail.com

M M Rashid, Department of Mechatronics Engineering, International Islamic University Malaysia. Email: mahbub96@gmail.com

A Rahman, Department of Mechanical Engineering, International Islamic University Malaysia. Email: arat@iiu.edu.my

A Hasan, Department of Mechanical Engineering, International Islamic University Malaysia. Email: aseuia@gmail.com

This model has been modified based on charging, voltage, SOC, and temperature equation which is proposed in this paper [12]. Nevertheless, the built-in model has limitation that is why it is not able to characterize the nonlinear current, voltage, SOC and temperature measurement of the battery pack [13]. Thus, the built-in model cannot give expected results that's why battery model is required to modify based on the charging equation. This demonstrate has been set up in MATLAB/Simulink in arrange to urge more expected result [14]. In this paper, battery charging, and temperature model has been established in MATLAB/Simulink. The battery parameters are modified based on expected outcome and experiment results. Additionally, battery model has been proposed based on battery model parameters which are SOC, charging current, voltage, and temperature. All of these parameters have been modified based on battery behaviors. First of all, LiFePo4 battery developed model and the structure of simulation blocks have explained in detail. Secondly, the charging characteristics such as charging time, Current, voltage, SOC, and temperature effect are analyzed by using MATLAB simulation program. Thirdly, battery test system and model extraction are presented in results and discussion respectively. Finally, overall discussion about battery model and concludes the paper.

II. THE PROPOSED MODEL

A. Battery Pack Model

The battery selection depends on its characteristic such as battery type, size, energy density, weight, cost, life cycle, efficiency, availability, and dependability. There are several types of battery which are using for various research for Examples Li-ion battery, lead-acid battery and Nickel ion battery. Nowadays, the LiFePo4 batteries are the most popular rechargeable batteries for EV. This battery has lots of benefits such as lightweight and powerful while it is compared to different rechargeable battery. This battery is capable to charge rapidly, and it can be manageable to charging storage ability and temperature while other batteries cannot allow rapid charging. In this study, MATLAB/Simulink has been used for developing the lithium-ion battery dynamic model. Figure 1 shows that, the overall dynamic model of lithium-ion battery which is proposed for this simulation. This dynamic model has been developed based on capacity, charging capability, temperature and time. This develop dynamic model is examined base on different conditions such as constant current-constant voltage, SOC, cycling, and temperature. The results have been analyzed base on applied conditions and The outcomes acquired by the simulation of the dynamic model are shown in Figure 1. Battery capacity has calculated based on SOC of battery and the other parameters of this model is dependent on voltage and charging current. MATLAB/Simulink is one of the foremost effective reenactment devices not only for circuit but also scheme designs. It has given lots of simple, powerful, various toolboxes and simulation blocks. A battery model has been developed for this simulation which has been included in MATLAB/Simulation /Simpower system. Moreover, the model is constructed based totally on battery charging

condition. A dynamic model of the lithium-ion battery based on the battery charging equation. For simulation study, a dynamic MATLAB simulation model with MATLAB/Simulink/Simpower has been proposed, which has presented in figure 1.

$$V_{batt} = E_0 - R \times i - K \frac{Q}{it - 0.1 \times Q} \times i^* - K \frac{Q}{Q - it} \times it + A \cdot \exp(-B \times it) \quad (1)$$

Where,

V_{batt} = Battery voltage (V)

E_0 = Battery constant voltage (V)

K = Polarization constant (V/Ah)

Q = Battery rated capacity (Ah)

$it = \int i \times dt$ = Actual battery charge (Ah)

A = Exponential zone amplitude (V)

B = Exponential zone time constant inverse (Ah)⁻¹

R = Battery resistance (Ω)

i = Battery current (A)

i^* = Filtered current (A)

This model can be work as an explicit model that's why we have divided into four parts like as charging model, SOC model, charge control model, and temperature model. These models have been merged after develop using MATLAB/Simulink, which has been shown in Figure 1. This model would be validated by comparing the simulation results. Figure 1 shows that the proposed simulation model has four sections (a) charging section, (b) current, voltage, and SOC measuring section, (c) control section, and (d) temperature section. All of these models has been developed separately and after that it has combined with MATLAB/Simulink where the terminal voltage of battery is presented with controlled voltage source while substances has used to control the battery charging model such as battery pack, SOC, temperature, battery voltage, and current. The current estimation block has utilized to allow the battery charging current esteem. The SOC is signified with SOC in it where the real time SOC has presented by SOCinit. The structure of each substance has explained in below.

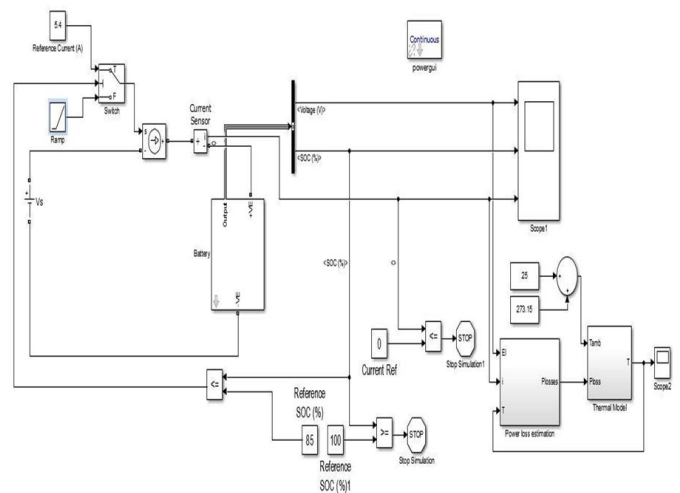

Fig.1. Overall dynamic charging model of MATLAB Li-ion battery



From figure 2 has been proposed the battery pack model on the Simulink model which has been developed for medium, fast and rapid charging. In this simulation, the battery pack consists only one battery module which make up a battery pack. Figure 3 shows the complete battery module which is implemented in this MATLAB Simulink.

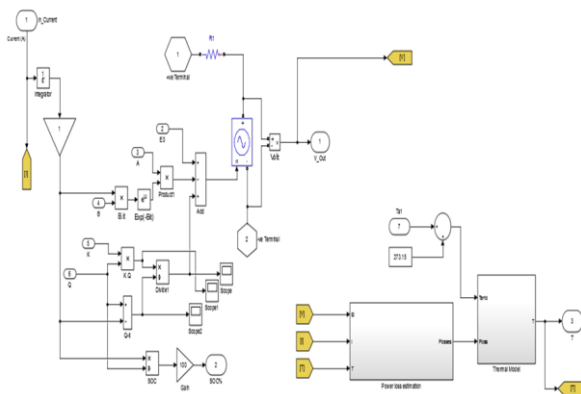

Fig. 2. MATLAB/ Simulink battery model

The LiFePo4 battery has chosen from MATLAB/Simulation parameters battery pack. There are several types of battery pack included in these packs but for this research it has been chosen only LiFePo4 battery pack. The MATLAB/Simulation battery pack has been modified based on this information which have been mentioned in table 1. This battery pack has been used after modifying battery paraments. The battery pack has been updated because it can support battery charging rate. If the battery parameters are not modified, then it is not possible to get accurate data from this simulation.

Table 1: MATLAB/Simulink battery pack parameters

| Parameters | Units | Value |
|--------------------------------|-------|---------------------|
| Battery Electrochemistry | - | LiFePO ₄ |
| Battery cell's nominal voltage | V | 25.6 |
| Battery cell's capacity | Ah | 2.7 |
| Battery charging current | Ah | 2.7, 3.37 |
| Battery initial SOC | % | 20 |
| Battery initial temperature | °C | 25 |
| Battery charging voltage | V | 28 |

B. SOC Calculation

The battery capacity equation has been utilized for SOC measurement where SOC_{init} is the initial of SOC, I denote charging current, 'tdt' represents time difference of battery charging, and 'Q' represents usable capacity of battery. The SOC has been calculated when all the battery parameters were updated. Figure 3 shows that the structure of MATLAB Simulink battery capacity model which have been developed based on charging equation 2. The capability model was created on the basis of various charging C-rate. SOC has controlled for this model because constant current can convert to constant voltage mode. From figure 1, it can be seen that, the SOC control parameter has been used to control battery SOC. This SOC control parameter will work when the SOC will reach around 85% at that time MATLAB/Simulink

switch block will be activated and it will switch battery charge CC to CV mode. The battery capacity model also developed based on equation. The SOC calculation equation has been mentioned below. Not only this model developed for SOC calculation but also charging current, voltage and charging temperature. The dynamic Li-ion battery model created, distinct temperatures, charging conditions are implemented and outcomes achieved by simulation of the model are shown in Figure 1 to 4.

$$SOC = SOC_{init} + \frac{\sum itdt}{Q} \quad (2)$$

Where

SOC_{inti} = Initial SOC of battery

I= Charging current(A)

t= time(hour)

dt= time difference of charging

Q= capacity of battery

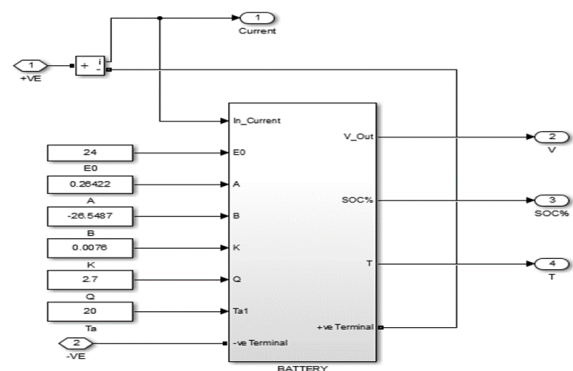

Fig.3. Capacity model of MATLAB Li-ion battery

C. Battery Charging Temperature Analysis

Battery temperature depends on cycle of battery charging, where battery temperature is increased dramatically, and it has exceeded of its allowable limit (45°C). Battery internal and ambient temperature has been played crucial role for battery cell performance. According to joule heating, battery internal temperature would be generated because of I²R losses,[10] if battery internal resistance is very low then, high current would be passed to the battery which is shown in Eq. (3). There are two sources to generate battery temperature such as change of entropy and ambient temperature of a battery. Battery temperature has been analyzed using overall energy balance equation which is exposed in Eq. (4). The battery temperature will be increased when the charging operation will CC mode after that temperature will increase slowly with CV mode. This switching operation will also maintain this simulation model. Figure 4 shows that, the battery temperature model which has been developed based temperature equation which is mentioned in below. The temperature model of the battery follows the following equation.

$$Battery\ temperature = Initial\ temperature + \frac{1}{C} \int \left(\frac{dQ}{dt} \right) dt \quad (3)$$

Where

C= the heat capacity of the battery pack



Q= the generated in the battery cell
 dt= time difference of charging temperature

$$T(t) = L^{-1} \left(\frac{Q_{gen} R_{th} + T_{amb.}}{1 + S t_c} \right) \quad (4)$$

The inner temperature (T) can be discovered at any moment (t) and displayed as follows.

where C_{cell} is the heat capacity of a cell, t time, T_{cell} the battery temperature, Q_{gen} the overall heat generation inside the cell, i charging/Discharging current, R_{th} is the internal resistance, T_{amb} ambient temperature, S the total surface area.

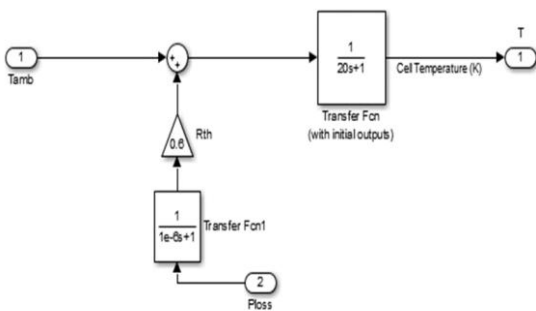

Fig. 4. Dynamic model of MATLAB Li-ion battery

III. RESULTS AND DISCUSSION

A. Fast charging

Form figure 5 shows that, this is constant current and constant voltage charging process. If the battery cell is not previously pre-charged at the initial stage, the battery would be pre-charged at low constant current. Then charging process is switched to a higher constant current but in this figure, it can be pragmatic that pre-charge already done that's why it was switched constant current mode. As shown on figure 5 that, the CC phase was incredibly lengthy compared of its CV stage for the fast charging even though C-rate was at 2C. The charging mode will be altered from CC to CV mode, when the voltage or SOC of the battery reaches to a certain value. Figure 5 shows a charging profile of a LiFePo4 battery. The charging system needs around 0.92 hours for full charging where the charging current is 2.7A. The battery initial charge was 18V and SOC was nearly 20%. This is fast charging process base on battery capacity. The battery charging rate was around 2C, which refers fast charging process. The main concern of this research is temperature response base on battery charging capacity. It can be observed that from figure 5 the initial voltage and charging current was 18V and 2.7A respectively but the supply voltage was battery charging requirement. The battery was charged rapidly from 0 to 8.5 minutes after that, the voltage level was increased gradually. The voltage level was around 25.13 volts. In between 9 minutes to 36 minutes, the voltage was increased steadily at that time the voltage values were 25.16 volts and 25.74 volts correspondingly. Additionally, the battery charging voltage was increased constantly from 36 minutes to 54 minutes, where the voltage values were 25.74 V and 26.02 volts respectively. The charging voltage was remained constant

when the battery voltage reached threshold point. When the battery state of charge reached to a certain threshold point at that time the charging process was changed to constant voltage unit the battery fully charged. On the other hand, from 0 to 38 minutes the charging current was constant where the value was 2.7A. Moreover, when the battery state of charge reached to a certain threshold point at that time the charging current was changed until battery full charged. This means that the charging voltage of the battery is regulated to keep the battery constant current while the charging current will switch from CC-CV at that stage charging current will decrease slowly. As the current dives to a lower esteem amid the CV stage. From 38 minutes to 54 minutes the charging current was decreased, where the charging current values were 2.7A and 0.0 A correspondingly.

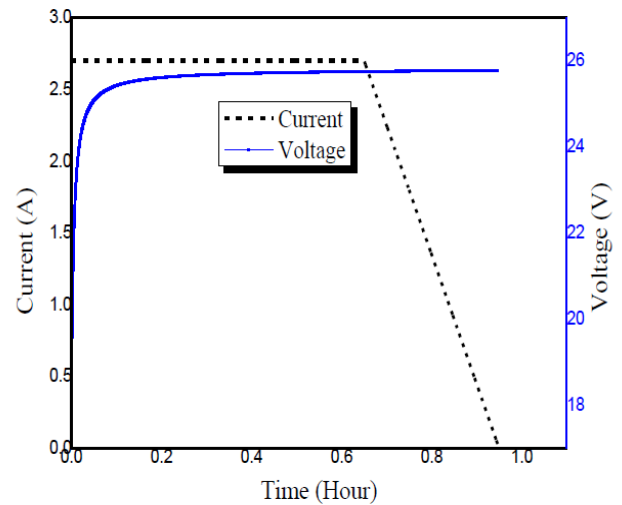

Fig. 5. Simulation results of CC-CV method for fast charging

From figure 6, it has been plotted SOC versus time curve and the SOC development throughout fast charging at 2C rate. The battery initial voltage was 18 Volts and initial SOC was 20 %. From 0 to 36 minutes battery takes charge rapidly at that time SOC was 85%. In between 0 to 36 minutes, the battery charge has reached around 85%, it means that SOC nearly 85% where the the CC stage shows a straight line due to the constant application of the charging current. The SOC has increased linearly versus time because of constant current method. The battery takes charge gradually until full charge after 36 minutes. The battery charges full and it takes 0.92 hours for fast mode.

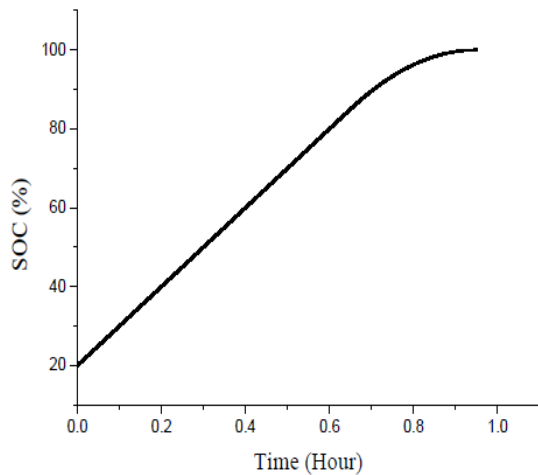

Fig. 6. Simulation result for the battery capacity during fast charging

Even though the battery charging time, battery temperature will be increased but this temperature depends on not only charging C-rate but also battery charging method. Figure 7 shows that the battery temperature would be maximum when the charging temperature is always increased until the constant current stage whatever the charge method. It has been referring that, the battery is warmed up amid the CC arrange while the charge switch from CC-CV at that stage battery temperature will increase slowly. During the constant voltage stage as the current drops to a lower value. Additionally, from 0 to 0.92 hours the battery temperature was raised rapidly while the charging current was 2.7A. The temperature figures were 25°C and 41.5°C respectively. This temperature figure refers that, it has been exceeded the temperature limit which will affect on Li-ion battery greatly. To avoid this temperature effect for this fast charging need to implement a thermal management system.

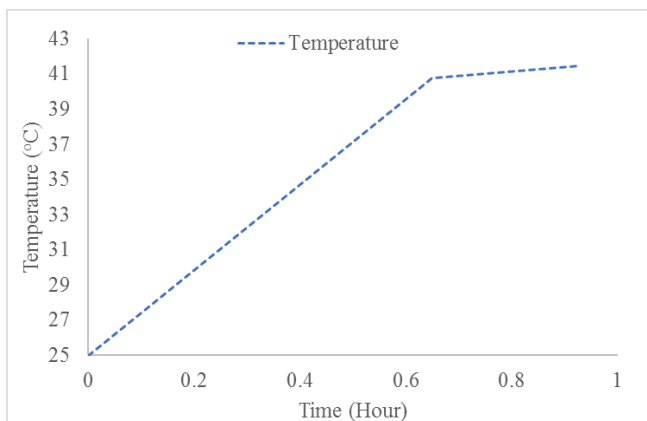

Fig.7. Simulation results of CC-CV method for fast charging

B. Rapid charging

Figure 8 shows a charging profile of a LiFePo4 battery. The charging system needs around 0.51 hours for full charging

where the charging current is 3.37A. The battery initial charge was 18V and SOC was nearly 20%. The battery charging rate was around 2.5C, which refers rapid charging process. The main concern of this research is temperature response base on battery charging capacity. The battery was charged rapidly from 0 to 6 minutes after that, the voltage level was increased gradually. The voltage level was around 25.13 volts. In between 6 minutes to 19 minutes, the voltage was increased steadily at that time the voltage values were 25.13 volts and 25.64 volts correspondingly. Additionally, the battery charging voltage was increased constantly from 19 minutes to 30 minutes, where the voltage values were 25.64 V and 25.75 volts respectively. On the other hand, from 0 to 30 minutes the charging current was constant where the value was 3.37A. Moreover, when the battery state of charge reached to a certain threshold point at that time the charging current was changed until battery full charged. This means that the battery charging voltage applied to the battery is controlled to maintain a constant current to the battery while the charging current will switch from CC-CV at that stage charging current will decrease slowly. Amid the CV arrange as the current dives to a lower esteem. Battery charging C-rate was 2.5C which refers rapid charging that's why the battery was charged around 85%. MATLAB simulation has been used for rapid charging based on C-rate that's why when the battery SOC will be reached around 85% at that time charging will be stop automatically. The battery was charged around 85% because of rapid charging.

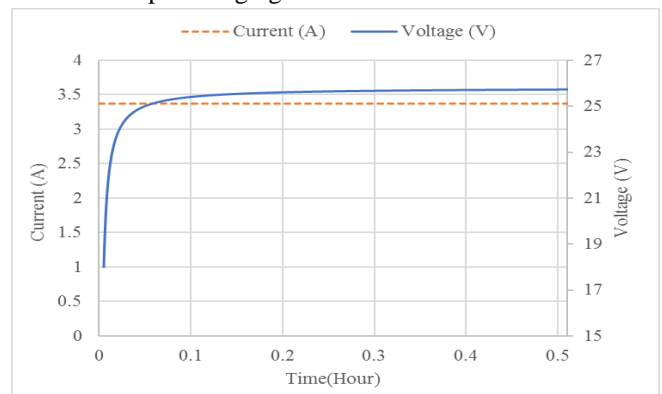

Fig. 8. Simulation results of CC-CV method for rapid charging

From figure 9, it has been plotted SOC versus time curve and the SOC evolution during rapid charging at 2.5 C rate. The battery initial voltage was 18 Volts and initial SOC was 20%. From 0 to 30 minutes battery takes charge rapidly at that time SOC was 85%. In between 0 to 30 minutes battery SOC is 85%, where the CC stage form a straight line because the current was applied constantly. The SOC will increase linearly versus time for a constant current method but here when the SOC will be reached around 85% at that time charging process would be stop. The battery charges around 85% and it takes 0.51 hours for rapid charging mode.

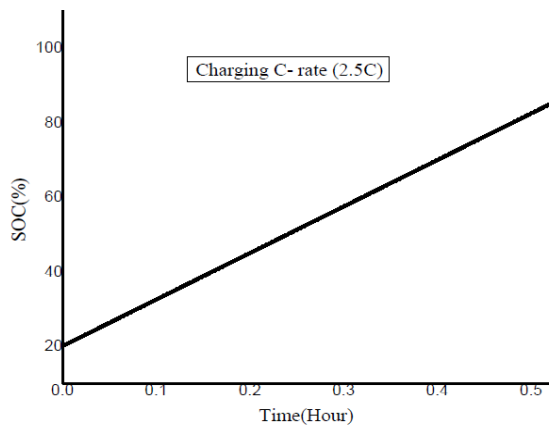

Fig. 9. Simulation result for the battery capacity during rapid charging

During the battery charging process, the battery experiences temperature increases that depend on both charging C-rate and charging method. Figure 10 shows that, the battery temperature would be maximum when the temperature is always concomitant with the end of the CC stage whatever the charge process. This implies that the battery is warmed up amid the CC arrange while the charge switch from CC-CV at that stage battery temperature will increase slowly. During the CV stage as the current plunges to a lower value. Additionally, from 0 to 0.51 hours the battery temperature was raised rapidly while the charging current was 3.37A. The temperature figures were 25°C and 55°C respectively. This temperature figure refers that, it has been exceed the temperature limit which will effect on Li-ion battery greatly. To avoid this temperature effect for this rapid charging need to implement thermal management system. This high temperature is capable to damage the LiFePo4 battery permanently.

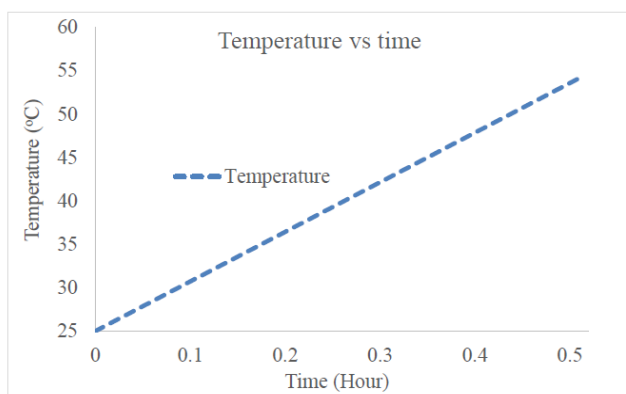

Fig. 10. Simulation results of CC-CV method for rapid charging

IV. CONCLUSION

This paper has been presented the temperature effect of fast and rapid charging technique based on charging C-rate. Battery pack should be charges rapidly and less time will take

for charging, this is another concern of this research. MATLAB/Simulation charging process is capable to charge the battery where it takes time approximately 54 minutes and 30 minutes respectively. The high charging C-rate is responsible to generate high temperature. This means battery temperature will depend on C-rate. Battery model has been developed based on SOC, terminal voltage, temperature, and charging current. High temperature can damage battery pack permanently that is why thermal management system should be used for battery safety and performance. The structures of each substance of this model have elucidated in detail. This model has been experimented and results have been discussed briefly. The constant current and constant voltage method have used for this model and get better performance based on charging C-rate.

REFERENCES

1. Wen, J., Y. Yu, and C. Chen, A survey on lithium-ion batteries security issues: existing issues and conceivable arrangements. *Materials express*, 2012. 2(3): p. 197-212.
2. Felgenhauer, M.F., et al., Assessing co-benefits of battery and fuel cell vehicles in a community in California. *Energy*, 2016. 114: p. 360-368.
3. Spotnitz, R., Simulation of capacity fade in lithium-ion batteries. *Journal of Power Sources*, 2003. 113(1): p. 72-80.
4. Zhao, K., et al., Break of terminals in lithium-ion batteries caused by quick charging. *Journal of Applied Physics*, 2010. 108(7): p. 073517.
5. Ramadesigan, V., et al., Modeling and simulation of lithium-ion batteries from a systems engineering perspective. *Journal of The Electrochemical Society*, 2012. 159(3): p. R31-R45.
6. Rashid, Muhammad Mahbubur, and Md Sazib Mollik. "THE DESIGN AND CONTROL SYSTEM OF SMALL ELECTRIC VEHICLE (EV): A REVIEW." 2016. 11: . 4154-4158
7. Gao, L., S. Liu, and R.A. Dougal, Energetic lithium-ion battery demonstrate for framework recreation. *IEEE transactions on components and packaging technologies*, 2002. 25(3): p. 495-505.
8. Inui, Y., et al., Simulation of temperature distribution in cylindrical and prismatic lithium ion secondary batteries. *Energy Conversion and Management*, 2007. 48(7): p. 2103-2109.
9. Khateeb, S.A., et al., Design and simulation of a lithium-ion battery with a phase change material thermal management system for an electric scooter. *Journal of Power Sources*, 2004. 128(2): p. 292-307.
10. Mizanur, R., M. M. Rashid, A. Rahman, AHM Zahirul Alam, S. Ihsan, and M. S. Mollik. "Analysis of the internal temperature of the cells in a battery pack during SOC balancing." In *IOP Conference Series: Materials Science and Engineering*, vol. 184, no. 1, p. 012014. IOP Publishing, 2017.
11. Tremblay, O., L.-A. Dessaint, and A.-I. Dekkiche. A generic battery model for the dynamic simulation of hybrid electric vehicles. in *2007 IEEE Vehicle Power and Propulsion Conference*. 2007. IEEE.
12. Chen, S., K. Tseng, and S. Choi. Modeling of lithium-ion battery for energy storage system simulation. in *2009 Asia-Pacific Power and Energy Engineering Conference*. 2009. IEEE.
13. Yao, L.W., et al. Modeling of lithium-ion battery using MATLAB/simulink. in *IECON 2013-39th Annual Conference of the IEEE Industrial Electronics Society*. 2013. IEEE.
14. Takano, K., et al., Simulation study of electrical dynamic characteristics of lithium-ion battery. *Journal of power sources*, 2000. 90(2): p. 214-223.
15. Klein, R., et al. Optimal charging strategies in lithium-ion battery. in *Proceedings of the 2011 American Control Conference*. 2011. IEEE.
16. Suthar, B., et al., Optimal charging profiles for mechanically constrained lithium-ion batteries. *Physical Chemistry Chemical Physics*, 2014. 16(1): p. 277-287.

AUTHORS PROFILE



Md. Sazib Mollik received the B.Sc (Eng) degree in electrical and electronic engineering from Bangladesh, World University of Bangladesh, in 2012, and the M.Sc degree in Manufacturing Engineering, from International Islamic University Malaysia in 2015 and Ph.D. (on going) degree in Mechatronics Engineering, International Islamic

University Malaysia since 2016 to ongoing. He is working as a research assistant in Mechatronics Engineering Department, International Islamic University Malaysia. He has published some papers in Indexed Journals, conference proceedings, and ISI. His research interests' smart materials, Electric and Hybrid Vehicles, and control engineering.



Muhammad Mahbubur Rashid (M'07) received the B.Sc. (Eng.) degree in electrical and electronic engineering from Bangladesh, University of Engineering and Technology, Dhaka, Bangladesh, in 1992, and the M.Sc. and Ph.D. degrees in electrical engineering from

the University of Malaya, membership, Kuala Lumpur, Malaysia, in 2003 and 2007, respectively. Since 2007, he has been working as an Assistant Professor and Associate Professor in the Department of Mechatronics Engineering/ course coordinator, International Islamic University Malaysia, Kuala Lumpur. He has published more than 600 papers in journals and conference proceedings. His research interests include advanced control system and simulation and nonlinear modeling, industrial automation, instrumentation, neural networks, artificial intelligence, power electronics, and renewable energy. (corresponding author)



Ataur Rahman Ph.D. is a Professor in the Department of Mechanical Engineering/Chairman IIUM Centre of Excellence of Electric Mobility, Faculty of Engineering, International Islamic University Malaysia since 1996.

His research interests are green transportation system: EV/HEV, hybrid engine, intelligent power train for hybrid and electrical vehicle, intelligent steering system and traction control system, electromagnetic actuated CVT and intelligent air-cushion vehicle for swamp and peat terrain.

He has worked in The University of Tokyo, Japan, as a Visiting Fellow on the development of integrated instrumentation systems for Autonomous Vehicles. He has published more than 800 Journal articles including 100 ISI listed journal from his research work.,



Abul Hasan received the B.Sc (Eng) and the M.Sc degrees in Mechanical engineering from Malaysia, International Islamic University Malaysia, in 2012, and 2015 and Ph.D. (on going) degree in Mechanical Engineering, International Islamic University Malaysia

since 2016 to ongoing. He is working as a research assistant in Mechanical Engineering Department, International Islamic University Malaysia. He has published some papers in Indexed Journals, and conference proceedings. His research interests' smart materials, Electric and Hybrid Vehicles.