

A High Gain EDFA Using Double-Pass Dual-Stage Amplification

Khalid A. al-Khateeb¹, Ali Sellami¹, Bouzid Belloui²

¹*Electrical and Computer Engineering Department
Kulliyyah of Engineering*

International Islamic University Malaysia

²*Faculty of Engineering, Multi-Media University Malaysia
khalid@iiu.edu.my*

Abstract

A new configuration of an Erbium Doped Fiber Amplifier is proposed. Double-Pass amplification in a Dual-Stage using a fiber loop-back is incorporated with a Tunable Band Pass Filter. Spontaneous emission is filtered-out in the mid-section to ensure efficient amplification of the signal as it propagates along the fiber. High gain of 54dB is achieved for -50dBm signal power at 1550nm. The two stages were pumped by laser diodes operating at 980nm with 10mW and 90mW respectively.

1. Introduction

Erbium doped fiber amplifiers (EDFA's) have attracted much attention for use in the third telecommunication window at wavelengths in the 1540-1560nm band [1,2]. Although much progress has been made in the development of high gain EDFAs, which form the backbone of high-capacity optical communications, fiber systems still suffer from loss due to different intrinsic characteristics of fiber materials. Hence, increased research effort is directed towards new materials and detailed system optimization [3]. Various configurations [5] have been proposed to increase amplifier gain and to reduce noise figures (NF), however to our knowledge there has been no report of results that go beyond a gain of 50dB.

The proposed system achieves a gain of 54dBs. It employs a dual-stage (DS) to enhance the amplification and a tunable band-pass filter (TBF) to filter out the backward amplified spontaneous emission (ASE) that degrades the signal amplification at the input end of the EDFA. The technique thereby reduces the effect of ASE self-saturation [2]. This configuration is also useful in reducing the sensitivity of the EDFA to extra strenuous reflections caused by

imperfections of the splices and other optical components [3,4] as well as improving noise figure and gain. Other reports have also shown that filters can be used together with the midway isolator to further suppress the forward ASE and improve the signal gain [6,7]. There are other approaches to obtain high gain by incorporating a double-pass (DP) in the EDFA [9,10].

This new architecture however, results in gain enhancement and a good NF using a relatively short erbium-doped fiber. The configuration is formed by a circulator CIR1 with four ports: port1 for input signal, port 4 for output, and other two are connected to circulators CIR2 and CIR3, each with three ports for the loop back signal and two for TBF's. This new architecture does not limit the possibility of other configurations. We believe that it may open the way for a new generation of EDFA's, as investigations continue.

2. Results and Discussions

The configuration of DS-DP is shown in Figure 1. The circulator CIR1 and the two circulators CIR2 and CIR3, which were used for signal feedback. The two TBF filters were incorporated between port3 and port1 of circulators CIR1 and CIR2. A 980 nm semiconductor laser is used as a pump source with a maximum power of 300mW. EDF1 is 7m in length and EDF2 is 10m, formed the first and second stages respectively.

Both EDF1 and EDF2 were characterized by a NA of 0.27, cutoff wavelength of 840 nm, and a peak absorption of 6dB/m at a signal wavelength of 1527nm, from which the erbium concentration is estimated to be 440 ppm Er³⁺ Core: silica /germania Calibration experiments showed that each turn consistently gave a signal attenuation of 12dB (three circulators CIR1, and two TBF filters). Thus the amplified signal propagates through CIR1 port1 to

port2, then through EDF1. As it propagates, it is subjected to the first amplification by EDF1. Between port2 into port3 of CIR2 it passes through the first TBF filter into port 1 and back to port 2 where it gets amplified again during the second pass through EDF1 into port 2 of CIR1. Then it continues to the second stage passing through EDF2 and CIR2. At port4 of CIR1 where the optical spectrum analyzer (OSA) is connected see Figure 1, the signal would have been influenced by a quadruple pass amplification of the two stages.

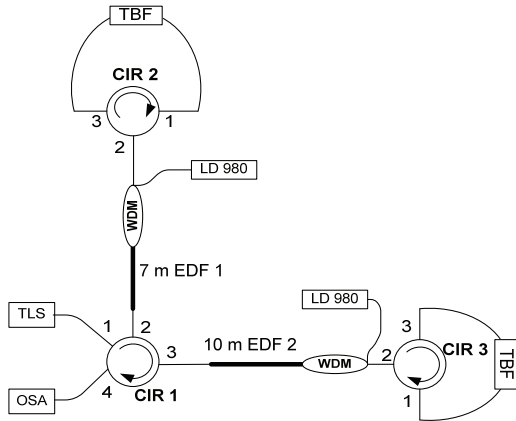

Figure 1: Experimental configuration of DS-DP

Figure 2 shows gain and NF against pump power at 1550nm signal wavelength for signal powers of -40dBm and -50dBm. The pump power has been optimized in this experiment; the first stage was fixed at 10mW and the pump power in the second stage was varied from 10mW to 90mW in 10mW steps. The gain value reached 41dB with only 10 mW pump power for both stages, recording a 4.1dB/mW gain coefficient with -50dBm input signal power. The gain increased gradually for both signal powers until it exceeded the 50dB mark at 80mW pump powers in the second stage for both input signal power of -40dBm and -50dBm. The highest gain of 54dB was obtained at 90mW pump power for -50dBm signal.

The NF plotted against pump power has shown a low decrease with an increase in pump power. The highest NF recorded value was 9 dB at 10 mW pump power at -40dBm input signal power.

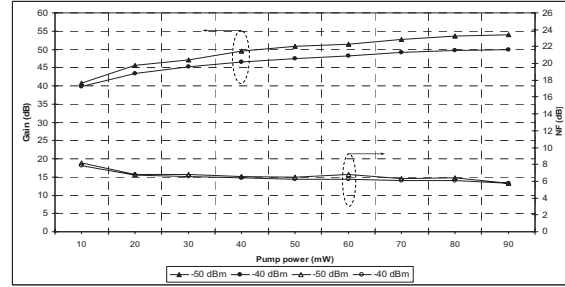

Figure 2: Experimental gain and noise figure against pump power at $\lambda=1550\text{nm}$ obtained using the DS-DPF.

Figure 3 illustrates gain and NF against input signal power at 1550nm signal wavelength. The pump power is set to 10mW and 90mW in the first and second stage respectively. The gain value decreases linearly with input signal power for the input signal powers > -40 dBm. There is no significant gain saturation in the small signal regime (< -40dBm). It is expected that the gain value can exceed 55dB if lower signal powers were used. The NF of the amplifier is recorded against input signal power. By increasing the input signal power the NF is increased also, when the signal power is above -25 dBm the NF reach its higher value between 7 and 14dB.

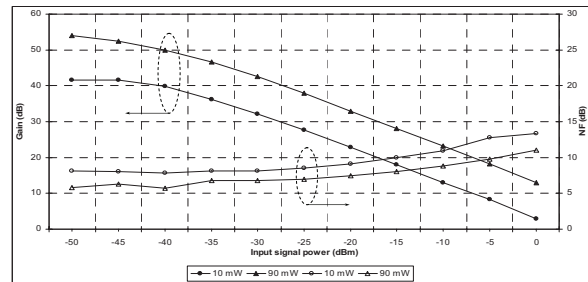

Figure 3: Experimental gain and noise figure against input signal power at $\lambda=1550\text{nm}$ obtained using the DS-DP.

The gain changes as a function of the amplified output power at different pump powers from 10 mW to 90 mW with a 20 mW step as shown in Figure 4. The wavelength is 1550 nm. It can be seen that both the output signal power and the gain increase with increasing pump power, and both have constant values on the two sides of the graph. The saturated output power of 3, 8, 10.5 11 and 13 dBm are obtained for pump power of 10, 30, 50, 70 and 90 mW, respectively.

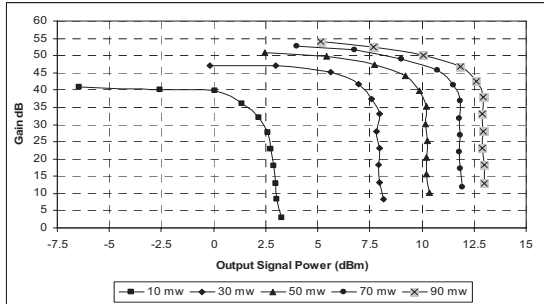

Figure 4: Experimental gain against the output signal power at $\lambda = 1550$ nm obtained using the DS-DP

3. Conclusion

The design of a new EDFA configuration with a Quadruple-Pass Amplification (QPA) in a Dual- Stage using a fiber loop-back, which incorporates a TBF, is proved to be effective in suppressing the noise generated by the ASE. Some important results are demonstrated, where gain as high as 41dB for -50dBm signal was obtained at 1550nm wavelength with only 10mW pump power for both amplifier stages. In addition, a new high gain value of 54dB is obtained at 10mW and 90mW pump powers in the first and second stages respectively. The fact that the gain values achieved with relatively short EDFA lengths and low pump power makes the design reasonably practicable, and opens the way for new design configurations that may lead to a new generation of EDFA's.

4. References

- [1] M. Horiguchi and H. Takata, "Transmission-loss characteristics of low-OH-content optical fibers," *Rev. ECL*, vol. 27, nos. 3 4 , pp. 226235,1979.
- [2] H. Osanai, T. Shioda, T. Moriyama, M. Horiguchi, T. Izawa, and H. Takata, "Effects of dopants on transmission loss of low-OH-content optical fibres," *Electron. Lett.*, vol. 12, no. 21, pp. 549-550, 1976.
- [3] J. L. Zyskind, J. R. Simpson, C. R. Gils, and E. Desurvire, "Optimization of erbium-doped fiber amplifiers pumped near 1.5 μ m," *Proc. SPIE*, vol. 1171 Fiber Sources and Amplifiers, pp. 137-144, 1989.
- [4] M. A. Mahdi, S. Thirumeni, P. Poopalan, S.Selvakennedy, F. R. MahamdAdikan,W. Y. Chan, and H. Ahmad, "Effects of self-saturation in an erbium-doped fiber amplifier," *Opt. Fiber Technol.*, vol. 6, no. 3, pp. 265-274, 2000.
- [5] C. Lester, K. Schusler, B. Pedersen, O. Lumholt, A. Bjarklev, and J. H. Povlsen, "Reflection insensitive erbium-doped fiber amplifier," *IEEE Photon. Technol. Lett.*, vol. 7, pp. 293-295, Mar. 1995.
- [6] H. Masuda and A. Takada, "High gain two-stage amplification with erbium-doped fiber amplifier," *Electron. Lett.*, vol. 26, no. 10, pp. 661-662, 1990.
- [7] R. I. Laming, M. N. Zervas, and D. N. Payne, "Erbium-doped fiber amplifier with 54 dB gain and 3.1 dB noise figure," *IEEE Photon. Technol. Lett.*, vol. 4, pp. 1345-1347, Dec. 1992.
- [8] W. I.Way, T. H.Wu, A. Y. Yan, M. Andrejco, and C. Lin, "Optical power limiting amplifier and its applications in an SONET self-healing ring network," *J. Lightwave Technol.*, vol. 10, pp. 206-214, Feb. 1992.
- [9] C. H. Kim, C. R. Giles, and Y. C. Chung, "Two-stage optical limiting fiber amplifier using a synchronized etalon filter," *IEEE Photon. Technol. Lett.*, vol. 10, pp. 285-287, Feb. 1998.
- [10] B. Bouzid, M. B. Ali, and M. K. Abdullah, "A high gain EDFA design using double pass amplification with a band-pass filter," *IEEE Photon. Technol. Lett.*, vol. 15, pp. 1195-1197, Sept. 2003.
- [11] B. Heens, X.Wang, L. Meuleman, F. Ravet, and M. Blondel, "Improvement of the EDFA design for both preamplifier and booster applications," in *Proc. Electrotechnical (MELECON 1998)*, vol. 2, 1998, pp. 1404-1408.