

BRIDGE SCOUR MONITORING BY COUPLING FACTOR BETWEEN READER AND TAG ANTENNAS OF RFID SYSTEM

M. I. Ibrahimy, S. M. A. Motakabber

Faculty of Engineering, International Islamic University Malaysia, 53100 KL, Malaysia

ABSTRACT: Bridge scour is an erosion which removes stream bed or bank material from bridge foundation due to flowing of water. Too much bridge scour is risky for the bridge foundation and causes sudden bridge to collapse without any warning. It implements significant impacts on the traveling public safety as well as the economy of the country. A number of parameters are associated with scour, thus different types of sensors are required to measure the individual affecting factor. A complex and expensive data logging from sensor and electronic communication systems are used to monitor the bridge scour in real-time to ensure the integrity of bridge structure. A high frequency band (13.56MHz) radio frequency identification (RFID) system has been proposed and that has been validated by simulation using PSpice software for the direct scour monitoring scheme, which is simple and low-cost. A number of passive RFID tags have been piled surrounding the bridge foundation which is continuously detected by the FRID reader. The erosion of the river bed carries out the RFID tag from nearby the bridge structure. As a result, the RFID reader can directly detect the absence of the tags as well as the amount of the scouring. Since, the design structure of the RFID system is simple, it is highly robust and easy to implement. The system can easily be implemented with an existing bridge structure and a wireless telemetry can be used to send the real-time data from the proposed system to a desktop computer in the monitoring lab.

Keywords: Scour, Bridge Monitoring, Riverbed Erosion, RFID, Passive Tag

1. INTRODUCTION

An RFID system is simple in its structure which consists of two main components only: the reader and the tag (transponder) with their antennas as shown in Fig. 1. A passive RFID system, the tag does not contain an onboard power supply and harvests the energy from the reader transmitted RF wave for its operation. Since the passive tag has no battery, it is simple, low cost, long life and easy to maintain. The RFID technology permits the wirelessly two-way transfer of information from a reader to a tag via RF waves transmitted through antennas. Two major advantages of the high frequency band RFID system (13.56 MHz) to make it suitable for monitoring the bridge scouring. First, it does not need line of sight between the reader and the tag for communication. Second one, it can easily communicate through the metal, water, soil etc. Therefore, the tag can be detected even when it is buried in the bed substrate of the bridge. The high frequency band RFID system (13.56 MHz) can easily communicate up to 100m distances. Generally, the tags are buried at predetermined locations (depths) side by side with known lengths. The tags are subsequently driven into the bed substrate at the location where bridge scour holes are expected within the detection range of the reader antenna, which are installed directly above the tags. The tags are kept perpendicular to the RFID reader antenna plane, so that they can be continuously detected.

Once the scour takes place, the tags are washed out and thus they are not detected. Therefore, the result indicates that bridge scours have been occurred at the known depth, where the tags are initially buried. That will reduce the huge cost of physical monitoring for bridge maintenance. Mobile communication can be used to transmit relevant information to bridge maintenance and management units and road users when a bridge would be potentially damaged by manmade or natural disasters. The instant conveying of information will allow the bridge management units to implement

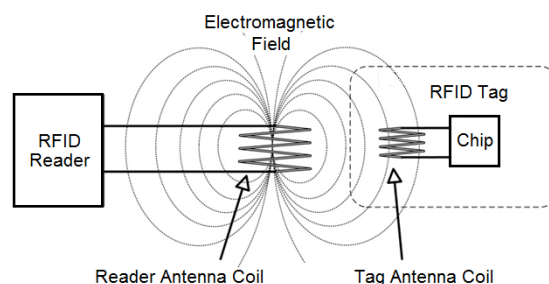

Fig.1 Basic RFID system

instant disaster rescue measures and to notify road users to avoid dangerous road sections, thus the people's lives and properties will be protected.

Bridge scour is the meaning of removal of soil, sand and rocks from around a bridge supports or piers as shown in Fig. 2. Rapidly moving water can wash out the river bed materials and make scour

holes, which can be threatening of the existence of a bridge structure [1]. Scour happens under the water and hard to see by naked eye. As a result, every year a number of bridges are collapsing all over the world and it damages lot of money and lives. The three main causes of bridge failure are collision, overloading and scour. It has been estimated that 60% of all bridge failure results occurred from scouring and other hydraulic-related causes [2].



Scour
Fig.2 Bridge scour [1]

Scour is a complex natural occurrence and a number of parameters are associated with it. Hence, to predict the bridge failures and real time scour monitoring, different types of sensors are required to measure the individual affecting factor [3, 4]. Among them sonar altimeter can be used to measure the distance between sensor and river bottom [5]. A change in distance-to-bottom is an indication of scour. Non-contact radar water level sensor can be used to measure the water level across a wide temperature range and varying water surface conditions [1]. Ultrasonic water velocity sensor and side-looking acoustic Doppler current meter can be used to measure bi-directional velocity of the water. The sensors read all the parameters including scouring, water levels and velocity of water flow. These sensor readings are transferred to a computer through wire or wireless communication systems. The reading is programmed to give an early warning to the computer. These sensors are generally selected and arranged based on local weather conditions, climate change effect, natural hazards and environmental conditions. Most of these type sensors are complex and very expensive.

2. DEVELOPMENT OF RFID SYSTEM FOR SCOUR MONITORING

Design and development of a low cost RFID system which is related to the bridge scouring, is an exciting matter. An RFID system consists of a tag reader (also called the interrogator) and a passive tag. All communication between the tag and reader ensures completely through a wireless link which is sometimes called an air interface. Through a sequence of commands sent and received between both devices called the inventory round. An RFID

reader can identify an object, location, orientation etc. through the RFID tag. Fig. 3 shows an RFID reader antenna coil and tag arrangement surrounding of a bridge pier. Each RFID tag has a unique number or code and the reader can sequentially

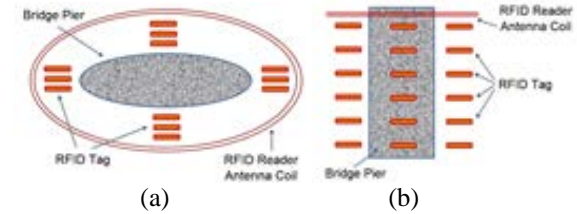

Fig. 3 (a) Cross sectional top view of the bridge pier and RFID tag arrangement (b) Cross sectional side view of the bridge pier and RFID tag arrangement

interrogate one by one of the tags with their code numbers. The tags are buried vertically in the river bed under the reader antenna coil as shown in Fig. 3(b) for the best performance. The scour will carry out the tag(s) from the vicinity of the reader antenna coil. As a result, no response will be found from the tag during the routine checkup of the reader by interrogation one by one of the tag with their corresponding code numbers. If a tag is not answered during the query of the RFID reader, the tag identification number gives a direct indication of the score position and its depth. For an improved service, the RFID reader can be interfaced with a wireless network communication system to communicate with the central control system, so that many bridge scour can be monitored simultaneously from a single place or a monitoring room.

The coupling factor between the RFID reader antenna and the tag antenna depends on geometrical parameters, distance and orientation of the antennas. In this case, the inductance values, number of turns of the coil of the tag are not involved. A simplified representation of the coupling factor k between a reader antenna coil and a tag antenna coil is represented by Eq. (1).

$$k = \frac{R_r^2 \times R_t^2 \times \cos(\theta)}{\sqrt{R_r \times R_t \times \sqrt{R_r^2 + d^2}}} \quad (1)$$

Here, R_r and R_t are the radius of the reader and tag antenna coil respectively, d is the distance between the coils and θ is the tilt along the axis of the coils.

3. DESIGN OF INDUCTIVE LOOP ANTENNA

Figure 4 shows the equivalent circuit of an inductive loop antenna.

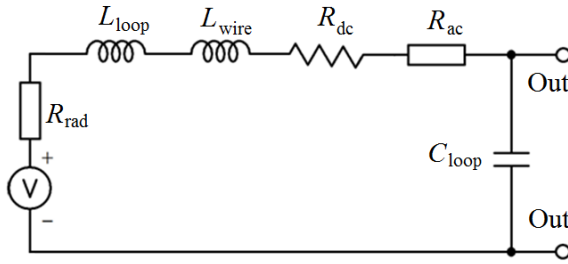

Fig. 4 Equivalent circuit of an inductive loop antenna

Radiation Resistance R_{rad} : Radiation resistance is one kind of losses in the antenna and it transforms the electrical energy into electromagnetic energy. Unlike an ohmic resistance that converts electrical energy to heat, this radiation resistance does not generate heat and thermal noise. The radiation resistance can be expressed by Eq. (2).

$$R_{rad} \approx 10^3 \pi^3 \left(\frac{NA}{\lambda^2} \right)^2 \quad (2)$$

Here, N is the number of turns; A is the area of the winding, in m^2 and λ is the wavelength, in m .

Loop inductance L_{loop} : It is the inductance of the wire winding around the frame. A square shaped air-core loop antenna's loop inductance can be expressed by Eq. (3).

$$L_{loop} = 8.0 \times 10^{-7} N^2 W \times \left[\ln \left(\frac{\sqrt{2} NW}{(N+1)l} \right) + 0.39 + \frac{0.33(N+1)l}{NW} \right] \quad (3)$$

Here, W is the frame side length, in m ; l is the length of the winding, in m .

Wire inductance L_{wire} : At HF the wire of the antenna windings has itself an inductance. A wire of length $4WN$ the wire inductance can be expressed by Eq. (4).

$$L_{wire} = 8.0 \times 10^{-7} NW \times \left[2.30 \log_{10} \left(\frac{16 NW}{d} \right) - 0.75 + \left(\frac{d}{8 NW} \right) \right] \quad (4)$$

Here, d is the wire diameter, in m .

Wire DC resistance R_{dc} : Any wire has a resistance that is a function of its length, diameter, and its material property. This resistance converts electrical energy into thermal energy and a source of thermal noise. The resistance of a wire of length $4NW$ and of diameter d can be expressed by Eq.(5).

$$R_{dc} = \frac{NW\rho}{\pi d^2} \quad (5)$$

Here, ρ is the resistivity of the wire, in $\Omega\cdot m$. For

copper $\rho = 16.78 \times 10^{-9} \Omega\cdot m$.

Skin effect and proximity effect resistance R_{ac} : At HF the current distribution in a conducting wire is no longer homogeneous, due to skin and proximity effects. These two effects states that, at HF less area of the wire is used to flow of current as a result; it imposes an AC resistance in the loop. The skin effect resistance can be expressed by Eq.(6).

$$R_{ac} = \frac{4NW}{\pi d} \sqrt{\pi \mu_0 f \rho} \quad (6)$$

Here, μ_0 is the permeability of free space equal $4\pi \times 10^{-7} H/m$ and f is the operating frequency, in Hz .

Distributed capacitance C_{loop} : The winging of the loop wire is formed distributed capacitance and its approximate value can be expressed by Eq.(7)

$$C_{loop} = 3.97 \times 10^{-13} \sqrt[3]{\frac{(400 W)^4}{\pi}} \quad (7)$$

A square shaped loop antenna is constructed by using AWG 20 copper wire. The following parameters are used to design the loop antenna as shown in Fig. 5.

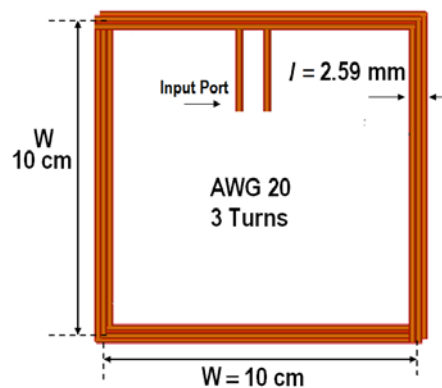

Fig. 5 Physical dimension of the loop antenna

- Number of turns, $N = 3$
- Length of each side of the loop, $W = 0.1 m$
- Diameter of the wire, d (bare) = 0.0008128
- Width of the coil, $l = 0.00259 m$
- Operating frequency, $f = 13.56 MHz$

The solution is obtained as follows:

$$\begin{aligned} R_{rad} &= 1.16 \times 10^{-4} \Omega \\ L_{loop} &= 2.96 \mu H \\ L_{wire} &= 1.9 \mu H \\ R_{dc} &= 1.57 \times 10^{-3} \Omega \\ R_{ac} &= 0.36 \Omega \\ C_{loop} &= 18.51 pF \end{aligned}$$

The total inductance of the coil is

$(2.96\mu\text{H} + 1.9\mu\text{H})$ $4.86 \mu\text{H}$ and distributed capacitance is 18.51pF . Actual values are slightly different than these calculated values.

The radiation resistance and DC resistance are very small compared with the AC resistance, so these can be neglected. The self resonance frequency of the antenna coil is 16.78 MHz . Therefore, a trimmer capacitor is used to tune the antenna with 13.56 MHz frequency. Figure 6 shows the final equivalent circuit of the antenna. Figure 7 shows the antenna series connection in the system.

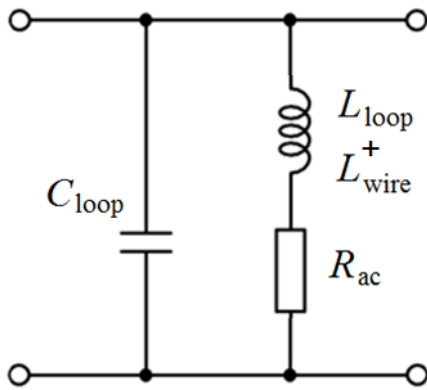

Fig. 6 Final equivalent circuit of the loop antenna

The values of the series capacitance and series resistance can be calculated as:

Considering the Q value of the antenna circuit is 60 then,

$$R_S = \frac{2\pi f_c(L_{loop} + L_{wire})}{Q} = \frac{2\pi \times 13.56 \times (2.96 + 1.9)}{60} \approx 7\Omega$$

The total capacitance of the circuit

$$C_T = (C_{loop} + C_S)$$

$$C_T = \frac{1}{4\pi^2 f_c^2 (L_{loop} + L_{wire})} = \frac{1}{4\pi^2 (13.56 \times 10^6)^2 \times 4.86 \times 10^{-6}} \approx 28.35\text{pF}$$

So, $C_S = C_T - C_{loop} = (28.35 - 18.51) \text{ pF} = 9.84 \text{ pF}$

4. RESULT AND CONCLUSION

Figure 8 shows the simulated graphical result of the antenna. It shows that the antenna acts like a series tuned circuit at a frequency about 13.5 MHz , and a peak current passes through it. In addition the antenna has worked as a parallel tuned circuit at a frequency about 17.0 MHz , and introduces maximum impedance.

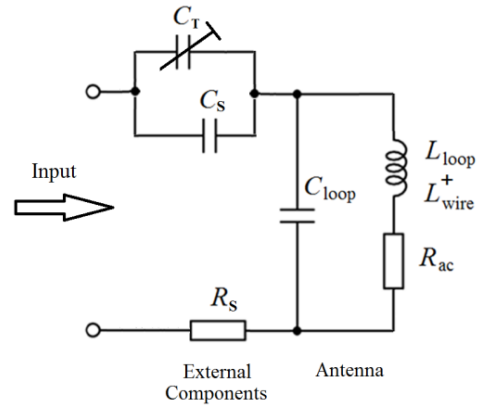

Fig. 7 Loop antenna is used as a series tuned circuit

The following parameters are used for simulation

$$L_{loop} + L_{wire} = 4.86 \mu\text{H},$$

$$R_{ac} = 0.36 \Omega,$$

$$C_{loop} = 18.51\text{pF}$$

The total series capacitance $(C_S + C_T) = 28.35\text{pF}$
Series resistance $R_S = 7 \Omega$

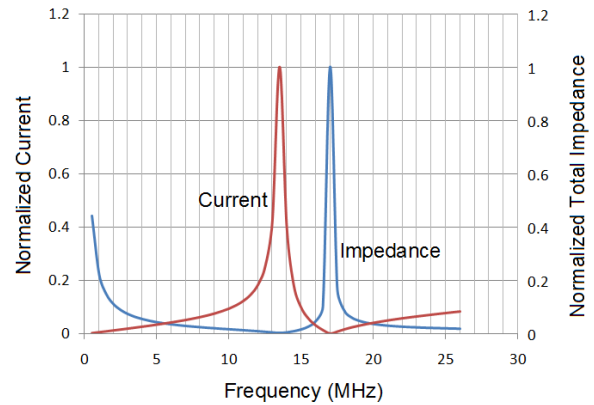

Fig. 8 Graphical simulated results

The PSpice simulation result of the coupling factor between a reader antenna coil and a tag antenna coil is represented by Eq. (1) is shown in Fig. 9. There are two bumps, instead of having a good single peak in the frequency response. These bumps, one for the tag antenna and the other for the reader antenna circuits respectively. It seems as two different resonant frequencies and which are well detached. This annoying effect is indeed what makes possible the design of an RF filter, made with cavities or helical resonators, slightly mistuned and carefully coupled to one another until the desired frequency response is obtained.

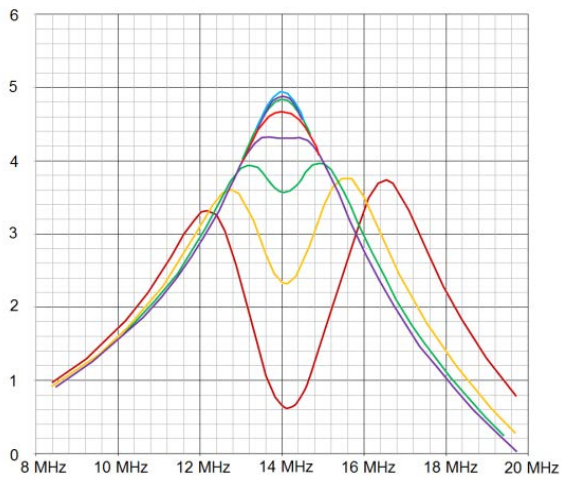

Fig. 9 Coupling factor between RFID reader and tag antenna coils

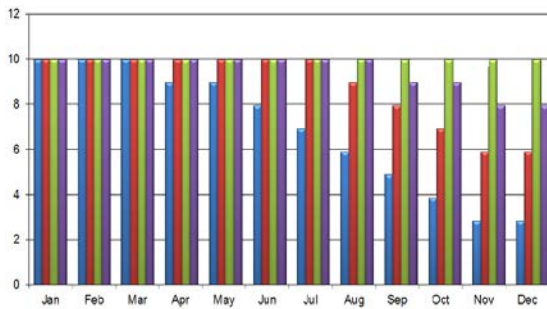

Fig. 10 Relation between scour and number of RFID tags

Figure 10 shows the relation between bridge scour and an RFID tags. In this simulation 4 bridge piers with 10 RFID tags for each pier has been considered. From April to October is considered as the monsoon season, the result shows that a scouring starts at pier 1 from the month of April to November and finally there is only 3 RFID tags are left surrounding of it. Similarly, scouring starts at pier 2 from the month of August to November and lastly, there is 6 RFID tags are left surrounding of it. Pier 4 also starts small scouring from the month of September. It is found that the bridge is in threatening condition of its existence due to huge scour with pier 1. Similarly, pier 2 also indicates moderate threatening to the bridge. However, the

others have not significant indications to the bridge. It can be concluded that during the monsoon season the probability of bridge scouring is high.

5. ACKNOWLEDGEMENTS

This research has been supported by the Malaysian Ministry of Science and Technology through the eScienceFund SF14-010-0060 entitled of the project “Design and Development of Chipless Ultra Wideband RFID System”.

6. REFERENCES

- [1] Anderson NL, Ismael AM and Thitimakorn T, “Ground penetrating radar: a tool for monitoring bridge scour”, Environmental & Engineering Geosciences, Vol. 13, No. 1, 2007, pp. 1-10.
- [2] Ballio F and Radice A, “A non-touch sensor for local scour”, Journal of Hydraulic Research, Vol. 41, No. 1, 2003, pp. 105-108.
- [3] Glaser SD, Li H, Wang ML, Ou J and Lynch T, “Sensor technology innovation for the advancement of structural health monitoring: a strategic program of US-China research for the next decade”, Smart Structure and System, Vol. 3, No.2, 2007, pp. 221-244.
- [4] Lin YB, Lai JS, Chang KC, Chang WY, Lee FZ and Ten YC, “Using MEMS sensors in the bridge monitoring system”, Journal of the Chinese Institute of Engineering, Vol. 33, No.1, 2010, pp. 25-35.
- [5] Lin YB, Chang KC, Chen CC, Wong SC, Lee LS, Wang YK and Gu MH, “Integrating real-time bridge scouring monitoring system with mobile location-based services”, International Journal of Automation and Smart Technology, Vol. 1, No. 2, 2011, pp. 51-62.

Int. J. of GEOMATE, June, 2015, Vol. 8, No. 2 (Sl. No. 16), pp. 1328-1332.

MS No. 4364 received on Aug. 5, 2014 and reviewed under GEOMATE publication policies.

Copyright © 2015, International Journal of GEOMATE. All rights reserved, including the making of copies unless permission is obtained from the copyright proprietors. Pertinent discussion including authors’ closure, if any, will be published in June 2016 if the discussion is received by Dec. 2015.

Corresponding Author: M. I. Ibrahimy