

Factors Influence Depositors' Withdrawal Behavior in Islamic Banks: A Theory of Reasoned Action

Muhamad Abduh, Jarita Duasa, and Mohd. Azmi Omar

Abstract—Unlike its conventional counterpart, Islamic principles forbid Islamic banks to take any interest-related income and thus makes deposits from depositors as an important source of fund for its operational and financing. Consequently, the risk of deposit withdrawal by depositors is an important aspect that should be well-managed in Islamic banking. This paper aims to investigate factors that influence depositors' withdrawal behavior in Islamic banks, particularly in Malaysia, using the framework of theory of reasoned action. A total of 368 respondents from Klang valley are involved in the analysis. The paper finds that all the constructs variable i.e. normative beliefs, subjective norms, behavioral beliefs, and attitude towards behavior are perceived to be distinct by the respondents. In addition, the structural equation model is able to verify the structural relationships between subjective norms, attitude towards behavior and behavioral intention. Subjective norms gives more influence to depositors' decision on deposit withdrawal compared to attitude towards behavior.

Keywords—Islamic bank, structural equation model, theory of reasoned action, withdrawal behavior

I. INTRODUCTION

THE risk management in financial institutions is one of the current financial issues, particularly during and after the global financial crisis 1997-1998 and 2007-2008. In association with the Islamic banking institutions, risk management is very important particularly to avoid bad impacts of the unfavorable economic/business conditions that may threaten the performance of the banks. For the Islamic banks, in addition to the traditional risks faced by the conventional banks such as credit, interest, liquidity, and operational risks, they are also facing other risks in accordance with their *shariah* based banking operations such as *shariah* risk, displaced commercial risk and withdrawal risk [4]. Interestingly, those risk i.e. *shariah* risk, displaced commercial risk and withdrawal risk are the enabler for depositors to withdraw their money from Islamic banks. Deposit withdrawal risk, therefore, is one of the most important risks to be managed by Islamic banks, particularly for those which operated in dual banking system country like Malaysia. Furthermore, there are another reasons why deposit withdrawal risk is very important. First, Islamic banks operate side by side with the conventional banks which requires them

to perform well and be profitable for their depositors. Second, Islamic bank depositors expect Islamic banks to pay competitive returns and provide comprehensive banking services (rational behaviors). Third, unlike its conventional counterpart, Islamic principles forbid Islamic banks to take any interest-related income and thus makes deposits from depositors as an important source of fund for its operational and financing. Therefore, the risk of fund withdrawal is another important aspect that should be given high attention by the Islamic banks. Since this type of risk is highly related with the withdrawal behavior of the depositors [1], therefore, it is very important to find out the determinants of depositors' withdrawal behavior in Islamic banks. Thus, this paper is aimed at investigating factors influence depositors' withdrawal behavior in Islamic banks.

II. LITERATURE REVIEW

A. Withdrawal Behavior in Islamic Banking

To date, there are still few studies done on Islamic banking depositors' withdrawal behavior. Some of these studies are [1], [2], [4], [5], and [16]. Reference [4] studies the depositors' withdrawal behavior and withdrawal risk in Islamic banking by using some mathematical notations and logic. It concludes that asset preservation in terms of minimizing the risk of loss due to a lower rate of return was an important factor influencing depositors' withdrawal behavior. Reference [5] supports findings in [4] by using a survey involving 468 respondents and covers three different countries i.e., 153 respondents from Bahrain, 165 respondents from Bangladesh, and 150 respondents from Sudan. The study in [5] reveals that:

- 1). Depositors would withdraw funds if there were rumors about the poor performance of Islamic banks.
- 2). In the short run, the lower rate of return would not force depositors to withdraw funds. But, in the long run, it might result to a significant number of depositors who took their funds from Islamic banks.
- 3). Depositors would shift their funds to other banks because they think that their current bank implements non *shariah* compliance products and practices.
- 4). Depositors would shift their funds to other banks if they found out that some parts of the banks' income were from interest income.

[16] uses linear probability model to identify depositors' withdrawal behavior and to analyze the responses of Islamic banks in Indonesia to mitigate deposit withdrawals. It comes up with three main reasons which can enable depositors to withdraw their money from Islamic banks [16]:

Muhamad Abduh is a graduate student at the Department of Business Administration of International Islamic University Malaysia (e-mail: abduh.iium@gmail.com).

Jarita Duasa is an associate professor at Department of Economics of International Islamic University Malaysia (e-mail: jarita@iium.edu.my).

Mohd Azmi Omar is a professor and dean of IIUM institute of Islamic Banking and Finance, Malaysia (e-mail: azmiomar@iium.edu.my).

- 1). Islamic banks do not generate incomes from their financing;
- 2). Interest rate goes up; and
- 3). Total deposits tend to decrease.

Meanwhile, [2] and [1] have conducted a direct survey toward Islamic bank depositors using self administered questionnaire in Jakarta, Indonesia. The former concludes that Islamic bank depositors shall go to withdraw their fund and switch to other banks if they do not find good performance in the most important dimension of Islamic bank service quality i.e., *shariah*-aspect, tangibles, and reliability. Meanwhile, the latter divided the factors that cause depositors to withdraw their money into general and specific factors. The general factor causes depositors withdraw their money is when the Islamic banks do not comply with *shariah*, and the specific factors are:

- 1). The willingness to adjust the tenor of deposits,
- 2). The need of funds for transactions, and
- 3). Less payment of return sharing on deposits than the previous period.

B. Theory of Reasoned Action

The theory of reasoned action (TRA) is a well-known model introduced in [6] to predict one's behavioral intention based upon his attitude towards behavior and subjective norms. This theory relies on an assumption that motives, values and attitudes are key components of any individual's decision-making process. This is due to the basic proposition held in TRA which states that behavioral intention determines actual behavior [6].

Reference [6] describes that one's behavioral intention is a function of his attitude towards behavior and subjective norms; subsequently, attitude toward behavior is determined by behavioral beliefs and subjective norms is a result of one's normative beliefs. Fig. 1 represents the TRA model in a structural form.

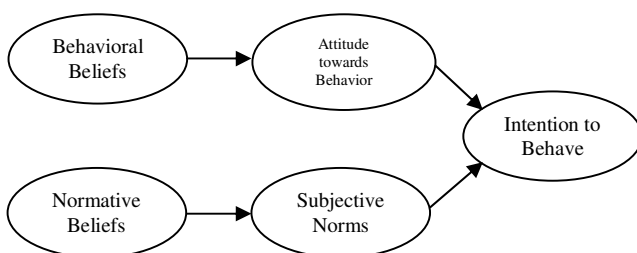

Fig. 1 The original framework of theory of reasoned action

The importance of intention on actual behavior also discussed in [23] after they do thorough research toward 60 research reports on behavioral intention study and conclude that if behaviors are not well learned or when they are performed in unstable or difficult contexts, conscious decision making is likely to be necessary to initiate and carry out the behavior. Under these conditions, results in [23] confirm that past behavior (along with attitudes and subjective norms) may contribute to intentions, and actual behavior is guided by

intentions. Many research had proven the significant influence of attitude towards behavior upon behavioral intention [3], [8], [9], [11], [12], [25], [27], [29] and subjective norms upon behavioral intention [3], [7], [8], [9], [11], [12], [22], [25], [28], [29], [31]. Furthermore, [13], [20], [29], [39] show that there is significant influence of one's subjective norms (SN) upon his attitude toward behavior (ATT).

In contrast with the number of researches conducted in conventional finance area using the framework of TRA (e.g. internet banking, mobile banking, home financing), similar researches within Islamic finance area are very scanty. Among studies in Islamic finance which uses TRA model are [3], [12], [13], [20], [25].

Reference [12] studies the intention of consumers in Malaysia to engage in Diminishing Partnership contract from Islamic bank for their home financing. Utilizing 300 questionnaires filled up by the respondents, attitude towards behavior and subjective norms are regressed with behavioral intention as dependent variable. The result indicates that both attitude and subjective norms are able to explain behavioral intention with subjective norms give more influence.

Meanwhile, [3] and [25] are both focus on the study of *zakah* payment behavior of Muslim employee and academics in Malaysia. The significant impact of attitude and subjective norm towards intention to pay *zakah* is able to be verified in [3]. However, [25] shows that only attitude towards behavior could significantly influence the intention to pay *zakah*.

Alternatively, [20] studies the intention of consumers in Malaysia to choose *halal* products. The findings indicated that the TRA is a valid model in the prediction of the intention to choose *halal* products. Attitude and subjective norm were found to be positively related to intention, with subjective norm being the more influential predictor. Subjective norm was also positively influence attitude towards choosing *halal* products.

Aiming for additional contribution in the application of TRA in the area of Islamic finance, the present study is intended to examine the following research questions (RQ):

- 1). To what extent the subjective norms can influence the intention to withdraw money from Islamic bank?
- 2). To what extent the attitude towards withdrawal behavior can influence the intention to withdraw money from Islamic bank?
- 3). To what extent the subjective norms can influence the attitude towards withdrawal behavior?

III. RESEARCH HYPOTHESES

Based on the literature review and research questions addressed (Fig. 2), the following are hypotheses developed in this study:

- 1). Subjective norms positively influence the intention to withdraw money from Islamic bank.
- 2). Attitude towards withdrawal behavior positively influence the intention to withdraw money from Islamic bank.
- 3). Subjective norms positively influence the attitude towards withdrawal behavior.

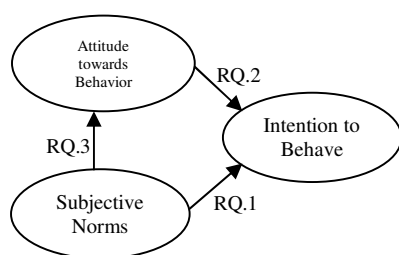

Fig. 2 The proposed theoretical framework

IV. DATA AND RESEARCH METHODS

A. Sample Size and Sampling Technique

Data used in this study are primary data obtained from a survey conducted on Islamic bank depositors within Klang Valley area of Malaysia. They are collected through a direct survey using self administered questionnaire. The study uses multistage sampling technique. Reference [18] argues that the use of multistage sampling is justified by economies achieved in sampling and data collection. The sampling economies are considerable with area sampling, where the lists from which elements are selected need be compiled only in the selected final-stage clusters such as a city, a city blocks or smaller segments [18]. Sampling technique in this study is started by cluster sampling in order to choose which city or area will enumerators go to collect the data required. In this case, Klang Valley was chosen as the area from where the information will be collected because this is the place where people from many area in Malaysia are coming and stay and where Islamic banks are mostly developed. Since there is no list of respondents, for the next step, convenience sampling will be applied to get a reasonable number of respondents from Islamic bank depositors.

Sample size formula for large population used in this study is adapted from [17]:

$$n_0 = \frac{z^2 pq}{e^2}$$

where:

- n_0 = Sample size
- z = Z-value of α (α in this study is 5%)
- p = Variability (variability used in this study is 0.5)
- q = 1 - p
- e = Level of precision or sampling error (sampling error tolerated in this study is 5%)

therefore, sample size is equal to;

$$n_0 = \frac{z^2 pq}{e^2} = \frac{(1.96)^2 (0.5)(0.5)}{(0.05)^2} = 385$$

Thus, as many as 385 respondents collected and intended to be incorporated in this study. Unfortunately, due to incomplete information given by some respondents, only 368 respondents are able to be included in the analysis which is 95.6 percent from the initial target.

B. Variables in the Analysis

There are 24 observed variables and 5 latent variables included in the analysis. The latent variables are intention to behave (BI), subjective norms (SN), attitude towards behavior (ATT), behavioral beliefs (BB) and normative beliefs (NB).

- 1). Behavioral intentions or intention to behave (BI). The TRA posits that the most proximal predictor for volitional behavior is one's behavioral intention. It is the result of both an individual attitude influence and normative influence. There are three observed variables refer to BI e.g., "I will definitely opt to withdraw my money from Islamic banks due to the reason of *shariah* non-compliance/lower rate of return/banking crisis".
- 2). Subjective norms (SN). Subjective norms or social norms are perceived social pressures exerted on an individual either to act or not to act. It also can be understood as a perception of whether people important to him think the behavior should be performed. There are three observed variables refer to SN e.g., "Most people that are important to me think that I should withdraw my money from Islamic banks due to the reason of *shariah* non-compliance/lower rate of return/banking crisis".
- 3). Attitude towards behavior (ATT). One key component to the TRA is an attitude toward engaging in some volitional behavior. There are seven observed variables refer to ATT e.g., "Withdrawing money from Islamic banks when I heard that they are violating *shariah* compliance in their products and management practices is the right action".
- 4). Behavioral beliefs (BB). Behavioral beliefs generally link some attributes to a volitional behavior or an attitude. There are seven observed variables refer to BB e.g., "Withdrawing money from Islamic banks when I heard that they were violating *shariah* compliance in their products and management practices allows me to avoid riba".
- 5). Normative beliefs (NB). Normative belief is the perceived expectation of important others regarding the volitional behavior. There are four observed variables refer to NB e.g., "My spouse and parents think I should withdraw my money when I found that my Islamic bank violating *shariah* compliance in their products and management practices".

C. Structural Equation Model (SEM)

Structural equation modeling (SEM) is a well-known method to analyze a survey data. It is a statistical methodology that takes a confirmatory approach to the analysis of a structural theory bearing on some phenomenon [10] and a comprehensive statistical approach to testing hypotheses about relations among observed and latent variables [15]. Nowadays, SEM is used by social, behavioral, and educational scientist as well as biologists, economists, marketing, and medical researchers.

[24] gives the following characteristics that are actually the main characteristics of SEM:

1. The models are usually conceived in terms of not directly measurable, and possibly not well defined, theoretical or hypothetical construct. For example, anxiety, attitudes, goals, intelligence, motivation, personality, reading and writing abilities, aggression and socio-economic status can be considered representative of such constructs.
2. The models usually take into account potential errors of measurement in all observed variables, in particular in the independent variables. This is achieved by including an error term for each fallible measure, whether it is an explanatory or predicted variable.
3. The models are usually fit to matrices of interrelationship indices—that is, covariance or correlation matrices—between all pairs of observed variables, and sometimes also to variable means.

Structural equation modeling (SEM) is basically comprises of two statistical traditions; (i) factor analysis which was developed in the discipline of psychology and psychometrics and (ii) simultaneous equation modeling which was developed in biostatistics and econometrics [19]. The steps in running SEM commence with the specification of a model to be estimated. The model tested is a statistical statement about the relations among variables [15]. Secondly, is to test the goodness-of-fit of the model proposed. Thirdly, test the relationship among the variables through some measurements and last is to interpret the results in relation with the model tested. A model fit test was carried out to determine whether the model should be accepted or rejected. If the model is accepted, the researchers can proceed to interpret the path coefficients in the model because "significant" path coefficients in poor fit models are not meaningful. Table I presents the model fit measurement and its cut-off value.

TABLE I
MODEL FIT INDICES AND ITS CUT-OFF VALUE

Measures ^a	Value	Interpretation
CMIN	p-value > 0.05	Accept the goodness-of-fit
NFI, TLI, RFI	> 0.80	Accept the goodness-of-fit
IFI, CFI	> 0.90	Accept the goodness-of-fit
RMSEA	< 0.08	Accept the goodness-of-fit

^a CMIN = the value of chi-square; NFI = Normed Fit Index; TLI = Tucker-Lewis Index; RFI = Relative Fit Index; IFI = Incremental Index of Fit; CFI = Comparative Fit Indices; RMSEA = Root Mean Square Error of Approximation.

V. RESULTS AND DISCUSSIONS

A. Reliability Analysis

Cronbach's Alpha was used to test the reliability of the research instruments. The values of cronbach's alpha should be greater than the minimum standard of 0.7 [21]. The result indicates good estimates of internal consistency reliability as the values ranged between 0.84 and 0.93 for each latent variable indicated in the model. Table II shows the values of cronbach's alpha for every latent variable in the theoretical model.

TABLE II
RELIABILITY ANALYSIS

Latent Variables	NoV ^a	Cronbach's Alpha
Normative Beliefs (NB)	4	0.927
Behavioral Beliefs (BB)	7	0.845
Subjective Norms (SN)	3	0.895
Attitude towards Behavior (ATT)	7	0.843
Intention to Behave (INT)	3	0.919

^a NoV = Number of observed variables

B. Factor Analysis

A factor analysis with varimax rotation was carried out to determine whether the respondents perceived all the constructs variable to be distinct. Factor loading of greater than 0.45 was used as cut off criteria. Although it is expected that factor analysis will give four factor as its solution, however, the results indicate that five loading factors is the best solution. Fortunately, only two items are mistakenly loaded to the unknown fifth factor i.e., ATT6 and BB6. As a consequence, those two items will not be included as an observed variable of its corresponding latent variable in the SEM model.

TABLE III
FACTOR ANALYSIS

Observed Variables	Factor1 (BB)	Factor2 (ATT)	Factor3 (NB)	Factor4 (SN)	Communalities
NB1			.771		.758
NB2			.797		.817
NB3			.861		.888
NB4			.817		.825
ATT1		.614			.700
ATT2		.756			.795
ATT3		.778			.760
ATT4		.777			.766
ATT5		.745			.754
ATT6					.740
ATT7		.519			.583
BB1	.726				.738
BB2	.793				.773
BB3	.797				.778
BB4	.758				.706
BB5	.739				.663
BB6					.748
BB7	.490				.522
SN1				.751	.818
SN2				.823	.869
SN3				.719	.786
Eigenvalue	10.606	1.665	1.478	1.086	

^aThe fifth loading factor is not included in this table for simplicity purposes. However, items of ATT6 and BB6 are left blank without loading value.

^bKMO Measure of Sampling Adequacy = 0.939; Bartlett's Test of Sphericity (Approx. χ^2) = 5851.1

Total variance explained is 70.64 percent, KMO measure of sampling adequacy is 0.939 and Bartlett's test of sphericity is significant ($\chi^2 = 5851.1$, p-value < 0.01). Reference [32] suggests that if a KMO measures exceed 0.9, then sample adequacy is considered very good. Table III presents the final result of factor analysis. It confirms that each of the latent variable (i.e. BB, ATT, NB, and SN) is perceived factorially distinct by the respondents and all the items used to measure a particular latent variable are loaded correctly except for ATT6 and BB6.

C. Structural Equation Model

Most researchers recommend reporting chi-square as the goodness-of-fit index of the model under the Maximum Likelihood Estimation (MLE). However, chi-square is sensitive to sample size. Reference [26] and [14] argue that with large sample size, the chi-square values will be inflated and reports statistically significant, which might erroneously imply a poor data-to-model fit. Reference [30] advocates not to use chi-square. To overcome the limitations of chi-square test, other goodness-of-fit indices could be used as substitutes to the chi-square statistic to assess the model fit such as RMSEA; the baseline fit measures (NFI, RFI, IFI, TLI, and CFI) and GFI under unweighted least square (ULS) method.

TABLE IV
MODEL FIT INDICES RESULTS

Measures	Value	Interpretation
CMIN	p-value < 0.01	Reject the goodness-of-fit
NFI, TLI, RFI	0.908; .926; 0.896	Accept the goodness-of-fit
IFI, CFI	0.935; 0.935	Accept the goodness-of-fit
RMSEA	0.078	Accept the goodness-of-fit

P-value for Chi –square (CMIN) is less than 0.01 which means we should reject null hypothesis. In other words, CMIN criteria reject the fit of the model. Baseline comparisons table, however, gives information about NFI, TLI, RFI, IFI and CFI measures which confirmed the acceptance of the goodness-of-fit of the model tested. The values of NFI, TLI, RFI are greater than 0.8, and IFI and CFI values are greater than 0.9. Besides, RMSEA value is less than 0.08 (0.078) which confirm the goodness-of-fit of the model tested (see Table IV). Hence, the results have confirmed that Islamic bank depositors' withdrawal behavior can be approached by the TRA framework.

D. Relationship Among Variables

On the acceptance of the TRA model's goodness-of-fit, the study proceeds to interpret the parameters estimated by SEM. The regression's weights are reported in Table V. Overall regression model is significant and meaningful due to their significant p-value at 1% alpha and estimated regression coefficients for the tested path diagram are greater than 0.2 (Fig. 3). These imply that all the three research hypotheses developed are supported.

The R² values for all endogenous variables, i.e. subjective norm (SN), attitude toward deposit withdrawal (ATT) and intention to withdraw (INT) are summarized in Table V. R² for subjective norm is 0.518 which means that 51.8% variation in subjective norms (SN) can be explained by normative beliefs (NB). The R² for attitude toward behavior is 0.693 which suggest that approximately 69.3% variation in attitude toward deposit withdrawal (ATT) can be explained by behavioral beliefs (BB) and subjective norm (SN). The third and final path has R² value equal to 0.719 which implies that more than 71% of intention to withdraw (INT) variation can be explained by its predictors i.e., subjective norm and attitude toward behavior.

TABLE V
RELATIONSHIP MODEL AMONG VARIABLES

Endogenous Variable	Exogenous Variable	ERC ^a	R ²
Subjective Norms (SN)	Normative Beliefs (NB)	0.657	0.518
Attitude towards Behavior (ATT)	Subjective Norms (SN)	0.289	0.693
	Behavioral Beliefs (BB)	0.757	
Intention to Behave (INT)	Subjective Norms (SN)	0.689	0.719
	Attitude (ATT)	0.320	

^aERC = Estimated regression coefficient from Exogenous to Endogenous variable(s).

These results meet the three objectives addressed in this study. Subjective norm is affecting depositor's intention to withdraw both directly and indirectly. Indirectly means that it influences depositor's attitude towards deposit withdrawal first before lead to withdrawal action. This implies that people and environment perceived important by depositors plays a significant role in influencing depositors' intention to withdraw when they encounter unpleasant circumstances within their Islamic banks.

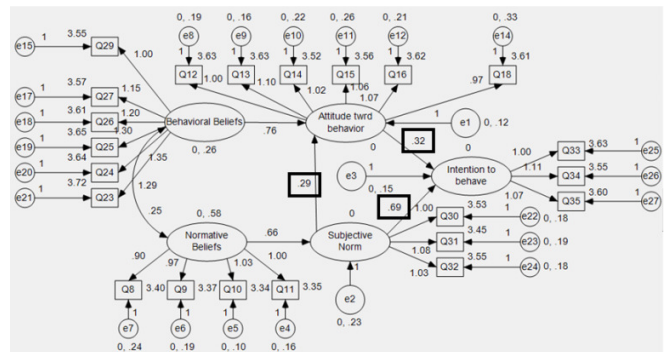

Fig. 3 The estimation results of proposed model using SEM

As a managerial implication for Islamic bank, it suggests at least two mitigation techniques in managing the risk of deposit withdrawal. First is by approaching those people and environment perceived important by depositors. In other words, Islamic banks must enhance their people-to-people relationship. For example, Islamic bank can go to Mosques, schools, universities or special communities to meet the Imams, teachers, lecturers, and leaders to explain unique features of Islamic banking and why they should remain with the bank.

Secondly, behavioral belief (BB) and normative belief (NB) are indirectly significantly affecting intention to withdraw (INT). These imply that approaching people and environment perceived important by depositors per se is not enough. Therefore, Islamic bank must also meet the belief and expectation of the depositors, both spiritually and materially. Islamic banks must not breach *shariah* principles in their products and practices and show better performance in terms of profitability and service quality.

VI. LIMITATIONS AND SUGGESTIONS

There are two limitations appear in this study. Firstly, it incorporates only individual depositors of Islamic banks without including corporate depositors. The second group of depositor is believed to have a different behavior in deposit withdrawal due to its nature in business and needs. Secondly, this study focuses in psychological aspect and skip over individual attributes such as gender, age, income and et cetera.

Therefore, in order to complement this study, the following suggestions can be considered in future researches. First is to include not only individual depositors but also corporate depositors in the analysis. Secondly, to include individual or organizational attributes to obtain better understanding on depositors' withdrawal behavior. Accordingly, more sophisticated statistical methods can be employed to test the hypotheses developed.

REFERENCES

- [1] M. Abduh and R. Ismal, "Depositors' withdrawal behavior in Indonesian Islamic banks (Periodical style—Accepted for publication)", *International Journal of Islamic and Middle Eastern Finance and Management*, to be published.
- [2] M. Abduh, "Islamic banking service quality and withdrawal risk: The Indonesian experience (Periodical style—Accepted for publication)", *International Journal of Excellence in Islamic Banking and Finance*, to be published.
- [3] Z. Abidin, M.K. Idris, and Faridahwati, "Predicting compliance intention on zakah on employment income in Malaysia: An application of reasoned action theory", *Jurnal Pengurusan*, vol. 28, pp. 85-102, 2009.
- [4] H. Ahmed, *A Microeconomic Model of an Islamic Bank*. Research paper No. 59, Islamic Research and Training Institute, Islamic Development Bank, 2002.
- [5] H. Ahmed, "Withdrawal risk in Islamic banks, market discipline and bank stability (Published Conference Proceeding style)", in *Int. Conf. on Islamic Banking: Risk Management, Regulation and Supervision*, Jakarta, 2003.
- [6] I. Ajzen and M. Fishbein, *Understanding attitudes and predicting social behavior*. USA: Prentice-Hall, 1980.
- [7] S. Al-Hajri, "The adoption of e-Banking: The case of Omani Banks", *International Review of Business Research Papers*, vol. 4, no. 5, pp. 120-128, 2008.
- [8] H. Amin, A. Abdulrahman, and T. Ramayah, "What makes undergraduate students enroll into an elective course? The case of Islamic accounting", *International Journal of Islamic and Middle Eastern Finance and Management*, vol. 2, no. 4, pp. 289-304, 2009.
- [9] H.H. Bauer, S.J. Barnes, T. Reichardt, and M.M. Neumann, "Driving consumer acceptance of mobile marketing: A theoretical framework and empirical study", *Journal of Electronic Commerce Research*, vol. 6, no. 3, pp. 181-192, 2005.
- [10] B.M. Byrne, *Structural equation modeling with AMOS: basic concepts, applications, and programming*. Routledge, USA, 2001.
- [11] F.D. Davis, R.P. Bagozzi, and P.R. Warshaw, "User acceptance of computer technology: A comparison of two theoretical models", *Management Science*, vol. 35, no. 8, pp. 982-1003, 1989.
- [12] M.T. Fauziah, T. Ramayah, and Dzuljastri, "Factors influencing intention to use diminishing partnership home financing", *International Journal of Islamic and Middle Eastern Finance and Management*, vol. 1, no. 3, pp. 235-248, 2008.
- [13] A.H.A. Gait, "Libyan attitudes towards Islamic methods of finance: An empirical analysis of retail consumers, business firms and banks (Unpublished work style)", Unpublished PhD Dissertation, Griffith University, Australia, 2009.
- [14] J.F. Hair, W.C. Black, B.J. Babin, and R.E. Anderson, *Multivariate Data Analysis*. Prentice Hall, 2009.
- [15] R.H. Hoyle, *The SEM approach: basic concepts and fundamental issues*, SAGE publication, USA, 1995.
- [16] R. Ismal, "Depositors' withdrawal behavior in Islamic banking: case of Indonesia". *Humanomics*, vol. 27, no. 1, pp. 61 – 76, 2011.
- [17] G.D. Israel, *Determining sample size*. Agricultural Education and Communication Department Series. Institute of Food and Agricultural Sciences, University of Florida, 1992.
- [18] G. Kalton, *Introduction to Survey Sampling*, SAGE Publication, USA, 1983.
- [19] D. Kaplan, *Structural Equation Modeling: Foundations and Extensions*, SAGE Publication, California, USA, 2000.
- [20] S. Lada, G.H. Tanakinjal, and H. Amin, "Predicting intention to choose halal products using theory of reasoned action", *International Journal of Islamic and Middle Eastern Finance and Management*, vol. 2, no. 1, pp. 66-76, 2009.
- [21] J.C. Nunnally, *Psychometric theory* (2nd Ed). U.S.A: McGraw Hill, 1978.
- [22] O.E. Omar, "The retailing of life insurance in Nigeria: An assessment of consumers' attitudes", *Journal of Retail Marketing Management Research*, vol. 1, no. 1, pp. 41-47, 2007.
- [23] J.A. Ouellette and W. Wood "Habit and intention in everyday life: The multiple processes by which past behavior predicts future behavior", *Psychological Bulletin*, vol. 124, no. 1, pp.54-74, 1998.
- [24] T. Raykov and G.A. Marcoulides, *A first course in structural equation modeling*, Routledge, USA, 2006.
- [25] R. Sapinci, N. Ahmad, and M. Mohamad, "A study on zakah of employment income: Factors that influence academics' intention to pay zakah (Published Conference Proceeding style)", 2nd International Conference On Business and Economic Research, 2011.
- [26] R.E. Schumacker and R.G. Lomax, *A Beginners Guide to Structural Equation Modeling*, Routledge—USA, 2004.
- [27] Y.Y. Shih and K. Fang, "The use of a decomposed theory of planned behavior to study internet banking in Taiwan", *Internet Research*, vol. 14, no. 3, pp. 213-223, 2004.
- [28] T.A. Shimp and A. Kavas, "The theory of reasoned action applied to coupon usage", *Journal of Consumer Research*, Vol. 11, pp. 795-809, 1984.
- [29] S. Taylor and P. Todd, "Understanding the information technology usage: A test of competing models", *Information System Research*, vol. 6, no. 2, pp. 144-176, 1995.
- [30] B. Wheaton, "Assessment of fit in over identified models with latent variables", *Sociological Methods and Research*, vol. 16, pp. 118- 154, 1987.
- [31] A.H.S. Zolait and A. Sulaiman, "Incorporating the innovation attributes introduced by Roger's theory into theory of reasoned action: An examination of internet banking adoption in Yemen", *Computer and Information Science*, vol. 1, no. 1, pp. 36-51, 2008.
- [32] H.F. Kaiser and J. Rice, "Little Jiffy Mark", *Educational and Psychological Measurement*, vol. 34, pp. 111-117, 1974.